

YRQ 800 Series



Design Features

Housing: Four heavy gauge .188 wall extruded aluminum sections interlock to form the cylinder housing. Two sections are internally welded to the cast lens frame and two sections are welded to the cast top, which is threaded to accept 1/2" nipple.

Mounting Bracket: The 1/2" nipple is threaded into the J-Box cover. (Cover provided by Contractor.) An air space of 3/4" must be maintained between luminaire and ceiling box.

Lens Assembly: Pyrex glass lens is sealed in regressed cast aluminum frame. The frame is welded to two extruded sections which easily slides down for relamping by releasing a single set screw. A safety chain secures the frame in place.

Optical System: Spun satin aluminum reflector produces a smooth symmetric distribution.

Socket: Porcelain mini-can lamp holder with nickel-plated shell and porcelain contact is rated for 500w 125v. T4/EI I mini-can lamps supplied by others.

Finish: Polyester powder coating on all metal parts. Color to be specified.

Listing: Luminaire is ETL listed.

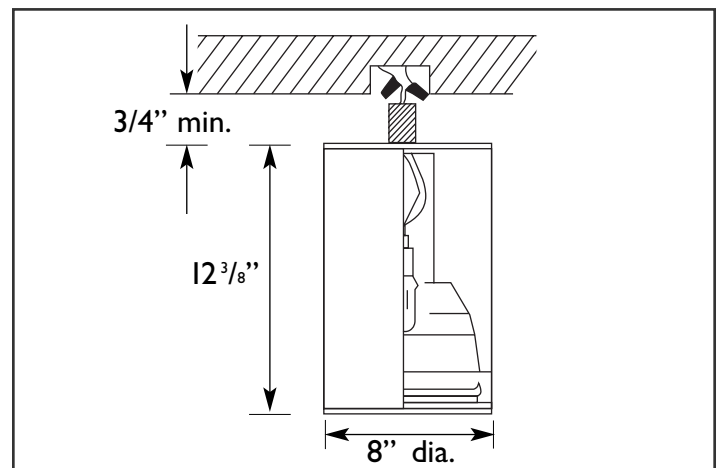

Specification Guide

Series	Wattage/Lamp	Volts	Options	Finish
YRQ	250w = 825Q	120	PM = Pendant Mount Specify Length WM = Wall Mount	BZ = Bronze BK = Black WH = White SL = Silver CC = Custom Color

Example: 250 Watt, Quartz, 120 Volts, Bronze
YRQ-825Q-120/IF/BZ